



agriculture & rural development

Department:
agriculture
& rural development
PROVINCE OF KWAZULU-NATAL

INVITATION OF QUOTATION ABOVE R30,000.00

THIS FORM SHOULD BE COMPLETED IN DETAIL AND SHOULD BE ACCOMPANIED BY A **VALID TAX COMPLIANCE STATUS PIN AND VALID BBBEE VERIFICATION CERTIFICATE/AFFIDAVIT**

QUOTATION NUMBER: R/S/1819/581	VALIDITY PERIOD OF QUOTATION..... Days (To be completed by the Supplier)
CLOSING DATE: 25/10/2018	CLOSING TIME: 11H00
DESCRIPTION(SPECIFICATION/S) OF ITEMS/ SERVICE REQUIRED. SUPPLY, DELIVER AND ERECT FENCING FOR NHLOKOYENKOMO PROJECT- UGU DISTRICT SEE ATTACHED SPEC	COMPANY NAME: TEL NO: FAX NO: CONTACT PERSON: CSD REG NUMBER MAAA.....
DOES OFFER COMPLY WITH SPECIFICATION?	YES/NO (DELETE WHICH EVER IS NOT APPLICABLE)
DOES ARTICLE COMPLY WITH SABS SPECIFICATION? HAS IT BEEN INSPECTED BY SABS?	YES/NO YES/NO (DELETE WHICH EVER IS NOT APPLICABLE)
DELIVERY PERIOD AFTER INITIAL ORDER?	
IS THE PRICE FIRM	
WHERE ARE THE STOCK HELD? (PHYSICAL ADDRESS , PLEASE)	
QUOTATION PRICE INCLUDING VAT (VAT TO BE ADDED BY REGISTERED VAT VENDORS ONLY)	TOTAL: R
COMPANY OFFICIAL STAMP (COMPULSORY) SIGNATURE OF BIDDER DATE
NUMBER OF PAGES FAXED BACK TO THE DEPARTMENT BY THE SUPPLIER(Supplier to complete)

HAND DELIVER QUOTATION FOR ATTENTION OF : MS BONGIE MBOKAZI CONTACT NUMBER: 033-355 9577

DOCUMENTS TO BE DEPOSITED AT THE BID BOX AT CEDARA: DEPARTMENT OF AGRICULTURE, 1 CEDARA ROAD

NB: THE ATTACHED SBD4 & SBD9 FORMS MUST BE COMPLETED IN FULL. THIS QUOTATION PAGE MUST BE COMPLETED AND RETURN WITH ALL YOUR QUOTATION DOCUMENTS.

COMPANY NAME :
 ADDRESS :
 CONTACT PERSON :
 CONTACT NUMBER :
 FAX NUMBER :

LINE NO.	DESCRIPTION OR SPECIFICATION OF ITEM	REQUIRED QUANTITY	UNIT PRICE EXCL. VAT		TOTAL PRICE	
			R	C	R	C
1.	To supply, deliver, offload, fencing material & erect fence at Nhlakoyenkomo project (32km from Harding) within Umuziwabantu local office under Ugu District					
	See attach attached Map, bill of quantities, fencing specs & bid document	4.59km				
* LABOUR (IF APPLICABLE)						
*DELIVERY (IF APPLICABLE)						
TOTAL						
*ONLY APPLICABLE TO VAT REGISTERED SUPPLIERS 15% VAT						
TOTAL PRICE						

*VAT Registration No. (Supplier) _____

When Required: 30 August 2018

Where Required: Nhlakoyenkomo project under Umuziwabantu local office, 32km from Harding

Contact details of requester: A.L. Silangwe / N.L. Ntshangase

TEL : 076 821 7430 076 510 7450

(COMPULSORY)

COMPANY STAMP

PRICES ARE VALID FOR 30 60 90 DAYS

Mark one Box (X)

SIGNATURE

DATE



REPUBLIC OF SOUTH AFRICA
MUNICIPALITY OF KENILDE-RAAL

MESH FENCING/ PREMANUFACTURED HINGED JOINT

>>> SUPPLY AND ERECTION <<<

BID DOCUMENT

Project: Nhlokoyenkomo Garden

TABLE OF CONTENTS

1.	Project Particulars and Specification	1-2	Read
2.	Bill of Quantities	4	Complete
3.	Drawing A1	5	Read
4.	Map of fence layout	6	Read

Appointment of a Service Provider to SUPPLY AND ERECT 4.59 kms of hinged joint fence at Nhlokoyenkomo Garden

1. Background:

The fence is to be erected approximately 37 km from Harding

2. Specific Objective:

Supply, deliver and fully erect a hinged joint fence of 4.585 km.
The fence must be erected in accordance with the specification in the attached drawing, Drawing A1.

3. Scope of Objectives:

Supply and erect a 1.2m hinged joint fence with 3 strands of double twist barbed wire above.
The following services are required:

- 3.1 Supply: - of the specified materials listed in the Bill of Quantities, Appendix 1.
- 3.2 Delivery: - of all materials to Project site
- 3.3 Erection: - according to the attached map, showing the fence layout.
- according to the Departmental Specifications in the attached drawing, Drawing A1.
- providing all equipment required for erection
- sourcing of at least 50% unskilled labour from the local community.
- 3.4 Inspection and reporting:
 - Weekly inspection reports of progress must be submitted on Monday morning to the contact person.
 - On site inspections will be conducted by Departmental staff to check all completed work before any payments can be made
 - The contractor is responsible to check that the tendered distance is correct. Failure to check the distance before starting the installation will result in the contractor not being paid for any excess/extra material that the contractor has purchased. The contractor will only be paid for materials that have been used. Where the tendered distance is lower than the required distance the contractor must not exceed the tender amount prior to receiving authorization in the form of a variation order.
 - Accurate distances of all erected fences are to be kept by the service provider as only work that has been done will be paid for. Any fencing installed over the order amount will not be paid for unless prior permission has been obtained to exceed the order amount.
 - Site meetings and project steering committee meetings to be held when necessary and minutes to be kept by the SP

4. Deliverables:

- 4.1 Fencing materials according to the Bill of Quantities in Appendix 1.
- 4.2 Construction of the fence according to the specifications provided in Drawing A1. If Drawing A1 was not attached to the tender documents it is the contractor's responsibility to obtain the drawing before submitting the tender. Failure to erect the fence according to the Departmental specification will result in the contractor having to re-install the fence at the contractor's own expense.
- 4.3 Weekly written progress reports to the Local Agricultural Manager, outlining progress, daily activities and quantities of materials used.
- 4.4 Submission of full closeout report including materials used, job opportunities created in EPWP format for the duration of the project.
- 4.5 Attendance of steering committee meetings and the provision of minutes if called for.
- 4.6 The contract requires a minimum delivery of 3 km of completed fencing per week.
- 4.7 Any excess material STRICTLY to be left with the project beneficiaries.

5. Competence and Expertise:

It is essential that the work be carried out by fully competent personnel with proven experience in fencing and Project Management.

- 5.1 Competency:
 - only bidders with proven ability to complete 3 km per week shall be considered.
 - bidders are required to provide an implementation plan including time frames from start to finish.
 - failure to provide a program will invalidate the bid.
- 5.2 Labour:
 - * skilled and semi-skilled labour only to be provided by the contractor. At least 50% unskilled labour is to be sourced from the local community.
- 5.3 Site supervision:
 - * Project Manager/Technician on site to supervise work done, quality control and certify work for payment. Estimated time for payment is 5 weeks.
- 5.4 Bid Format:
 - All documents in the bid document are to be completed. All quotations and claims must include VAT.

6. Validity Period for Bid:

Bids shall remain valid for a period of 90 days from the date that the bid closes.

7. Compulsory Pre-Bid Tender Meeting:

A compulsory pre-bid site meeting will be held with prospective bidders. Failure to attend this meeting will invalidate the bid.

8. Site Hand Over to the Contractor:

The contractor will be introduced to the project participants following the awarding of the tender. The site will be handed over to the contractor who will control the site for the duration of the project. The contractor will be responsible for the administration, control and security for the site. It is up to the contractor to arrange insurance as the contractor is responsible for and theft or damage that occurs on site and will have to pay.

9. Water and Electricity:

There is no piped water and electricity on site. The contractor shall make the necessary arrangements for the provision of any water and electricity. Any cost to acquire water and electricity must be added to the bid amount as no extra funding will be received.

10. Housing of Contractors Employees:

No housing is available for the contractors employees and the contractor shall make arrangements to and from site. It is up to the contractor to arrange any short term accommodation with the project participants. The contractor is responsible for any financial expenses for housing employees on site.

11. Underground Cables and Pipes:

If such services are discovered, immediate notification must be made to the Employer and all work in the vicinity will cease until it is safe to continue. If the contractor damages any underground pipes or cables such damage will be repaired as soon as it is safe and possible by the contractor.

12. Insurance

All accepted approved contractors shall be required to provide the following insurance's for the project awarded to them:

- i) Registration with the Compensation Commissioner and compliance with the Compensation for Occupational Injuries and Diseases Act with regard to insurance.
- ii) Unemployment fund insurance for all workers.
- iii) Insurance against damage, destruction or loss caused by fire.
- iv) Public Liability Insurance.
- v) All Risks (works) Policy Political for the value of the respective project plus 10%.

13. Specification:

Refer to Bill of Quantities and Drawings.

Spacing of wooden poles: 5.0m;

10% maximum deviation (0.5m) from the specified spacings will be allowed.

Boxes: Box length to be 1.05m (half a pole length).

Construction: Normal manual force against the poles must be absorbed.

Strainings: The hinged joint section & barbed wire to be strained. If the fence is pulled down, it must recover to it's original position.

Fence is to be strained using appropriate straining equipment.

Exposed Surfaces: All exposed surfaces where poles have been sawed off are to be painted with creosote.

14. Timetable/Timing:

The contractor must be on site and commence construction no later than 1 week after an order has been issued. Where more than 1 payment is required, the contractor must indicate the number of part payments that will be required in the tender documents. Claims for work that has been completed and verified can be submitted on a monthly basis. No more than 1 claim per month will be accepted.

15. Management Arrangements and Reporting Requirements:

Mr. N M Ngungama is the District Manager. Any matters regarding the district staff or any complaints should be directed to him/her.

16. Evaluation Criteria:

Proven previous experience is a requirement to qualify.

The following minimum CDB designations are required:

Farm fencing (barbed/razor wire/hinged joint) < 5km:	150/CE/BB
Farm fencing (barbed/razor wire/hinged joint) 5 - 15km:	250/CE/GB
Farm fencing (barbed/razor wire/hinged joint) > 15km:	350/CE/GB

TABLE 1A: Minimum CDB designation requirements per length of fencing bracket

Award of work to the successful bidder will be based on Price, Departmental Goals (i.e. preference points as per ZNT 3D attached) and functionality.

16.1 Compliance:

- i) All information and documentation required in the Specification, eg. Certificates.
- ii) All information required in the bid document must be accurate and duly completed, including all the appropriate signatures. This includes the submission of required / requested documentation eg. valid tax certificate, ZNT 3D etc.
- iii) Failure to comply with any of the requirements will invalidate the bid.

16.2 The 80/20 and 90/10 Preference Points System:

(i) Depending on the bid value either the 80/20 (for bids up to R 1,000,000) or the 90/10 point preference point system (for bids of R 1,000,000 and more) shall be applied. Qualifying for preferential points is entirely based on the B-BBEE status of the bidder as explained below.

(ii) **CALCULATION OF POINTS FOR ATTAINING THE B-BBEE STATUS LEVEL.**
This will be done in accordance with the "PREFERENTIAL PROCUREMENT POLICY FRAMEWORK ACT, 05 OF 2000 AND REGULATION OF 2011". Points will be awarded to a bidder for attaining the B-BBEE status level contributor. Below is the table illustrating points to be allocated at different levels.

B-BBEE Status Level of	Number of points	Number of points
1	10	20
2	9	18
3	8	16
4	5	12
5	4	8
6	3	6
7	2	4
8	1	2
Non-compliant bidder	0	0

TABLE 1B: Preference points per BBEE status level

PLEASE NOTE: Bidders are required to, together with their bids, submit original and valid B-BBEE Status Level Verification Certificates or certified copies thereof to substantiate their B-BBEE rating claims. Bidders who do not submit B-BBEE Status Level Verification Certificates do not qualify for preference points for B-BBEE but will not be disqualified from the bidding process for non-compliance in this regard.

(iii) **FUNCTIONALITY**
Functionality will be assessed separately from the 90/10 or 80/20 formula. The first stage will be the assessment of functionality upon which the Bidders who score less than 65% for functionality will not be considered further. The second stage will be the assessment and evaluation of Bidders in terms of 90/10 or 80/20, where 90 (80) points shall be used for pricing scores only and the 10 (20) points for BBEE status. See Tables 2 and 3 for Evaluation Guidelines and Criteria respectively.

TABLE 2: GUIDELINES FOR EVALUATION

CRITERIA	GUIDELINES FOR EVALUATION
ABILITY	Bidders to provide proof of current capacity and ability to implement (in design and specifications) to the standard as directed in the technical specifications.
CAPABILITY	Demonstration of competency to render the required service & providing proof of registration with the CIDB (for which CIDB designation requirements are Table 1A)
Competency & Experience	Bidders to provide evidence of similar projects completed recently (i.e. not less than 2 projects and not more than 5 projects in the past 5 years.
METHODOLOGY	Provide a short description of your intended implementation methodology indicating time frames to complete the work.

NOTE: In order to verify financial stability, bidder must submit detailed information or substantiation of the evaluation criteria mentioned.

TABLE 3: ASSESSMENT CRITERIA FOR THE EVALUATION OF THE FUNCTIONALITY

EVALUATION MATRIX	Points	Score
1. Financial stability of the bidder: Submission of a letter of good standing from a recognized financial institution	10	
2. Submission of short CV's of key personnel: • Demonstration of competency to render the required service (e.g. CIDB registration certificates). • Providing proof of insurance. • Proof of compliance with labour legislation (enrolment of staff for employer's compensation/WH, Occupational Health & Safety Act)	20	
3. Demonstrable experience of the prospective service provider's engagement in similar work: • Submission of list of 2 - 5 projects in the last 5 years with nature and extent of involvement and contact details of referees. • Documentary proof such as reference letters/CIDB assessments indicating value and period of the contract.	35	
4. Submission of a short description of the intended implementation methodology indicating time frames to complete work.	10	
TOTAL	100%	

Submissions will be scored using the below scoring table. This bid will be evaluated on functionality which will determine the capability, ability and capacity of the prospective bidders to provide the required goods or services for the department. A minimum score of 65% must be obtained by the bidder in order to qualify to be evaluated further for price.

16.3 General:
The Department of Agriculture, Environmental Affairs and Rural Development is an equal opportunity, affirmative action employer. It shows the same commitment to those who wish to provide services to the Department via the procurement process. This does not preclude the formation of consortiums or the inclusion of proposals on how this project can be used to further the aims of transformation. The actual price quoted, including VAT, will be used for issuing of an order to the successful bidder. You must provide for all items in Appendix 1 as the unit rates quoted will be applied for calculation of the amount claimable.

17. Payment Schedule:

Claims for work that has been completed can be made according to the following payment schedule:

1 Site Establishment:	5%
2 Material delivered to site (with Invoices)	Invoiced Amount
3 Completed sections of fence (per m)	pro rata tender amount (less 1+2+4)
4 Retention	5%

A 5% retention will be kept for 3 months after works have been completed to make sure that the standard of work that has been done is satisfactory.

18. Enquiries:

Mr. N M Ngcungama District Manager
Miss. A. L. Silangwe Project manager

Contact Number
Contact Number

0996822045
0768217430

APPENDIX 1: BILL OF QUANTITIES

FOR THE SUPPLY OF MATERIALS FOR AND ERECTION OF A

1.2m Hinged joint fence with 3 strands of barbed wire above (Total Height 1.7m)

Version 4.0 September 2013

Project: Nhlakayenkomo Garden
Fence Perimeter = 4585 m
District: Bzi ngolweni
Contact Person: Miss. A. L. Silangwe
Contact Number: 0768217430

No.	Item Description	Quantity Required		Unit Price	Total Cost
General:					
1	Site establishment.	Sum	1		
Site Clearing:					
2	Removal of any existing fences. Bush clearing required.	Sum	1		
Materials:					
3	Fully Galvanized barbed wire 1.6mm diameter High Tensile double strand 845m per roll Galvanized Class <input type="text" value="B"/>	19	Roll(s) of 845m length		
4	2.4m Standard Creosote Poles Pressure treated, SABS approved 100 - 125mmØ	1278	Poles		
5	Hinged Joint Fence, 1.2m high (eg. Veldspan/Bannonx/or equivalent) Galvanized Class <input type="text" value="B"/> Vertical wire apertures:150mm. Horizontal wires at 75/88/102/114/127/140mm. 100m rolls	52	Roll(s) of 100m length		
6	Galvanized Wire Staples 3.15 x 32mm 500g packs	152	Pack(s)		
7	Gate: 900 (w) x 1800 (h)mm pedestrian gate Hot dip galvanized finish 40 - 50mm diam pipe frame wall thickness of 1.6mm min Hinge eye bolts, include chain	2	Gate(s)		
8	Gate: 3600 (w) x 1800 (h)mm Vehicle farm gate Hot dip galvanized finish 40 - 50mm diam pipe frame wall thickness of 1.6mm min Hinge eye bolts, include chain	2	Gate(s)		
9	Gate: 2400 (w) x 1800mm (h) tractor gate (2 frames per gate, HDG finish, 40-50mm diam pipe frame, wall thickness 1.6mm min - hinge eye bolts - include chain	0	Gate frames		
10	8 ga straining wire, 4mm diam, 5kg(50m) rolls Galvanized Class <input type="text" value="B"/>	19	Roll(s)of 5kg		
11	12 ga binding wire, 2.5mm diam, 5kg (130m) roll Galvanized Class <input type="text" value="B"/>	1	Roll of 5kg		
12	Erection Cost	Sum	1		
13	Transport Cost, including loading, delivery and off-loading	Sum	1		
SUB-TOTAL					
VAT					
TOTAL					

NOTE: This Bill of Quantities must be read in conjunction with DRAWING no. A1 Dated 22/10/2010

IZG: Nhlokoyenkomo Cropping Project

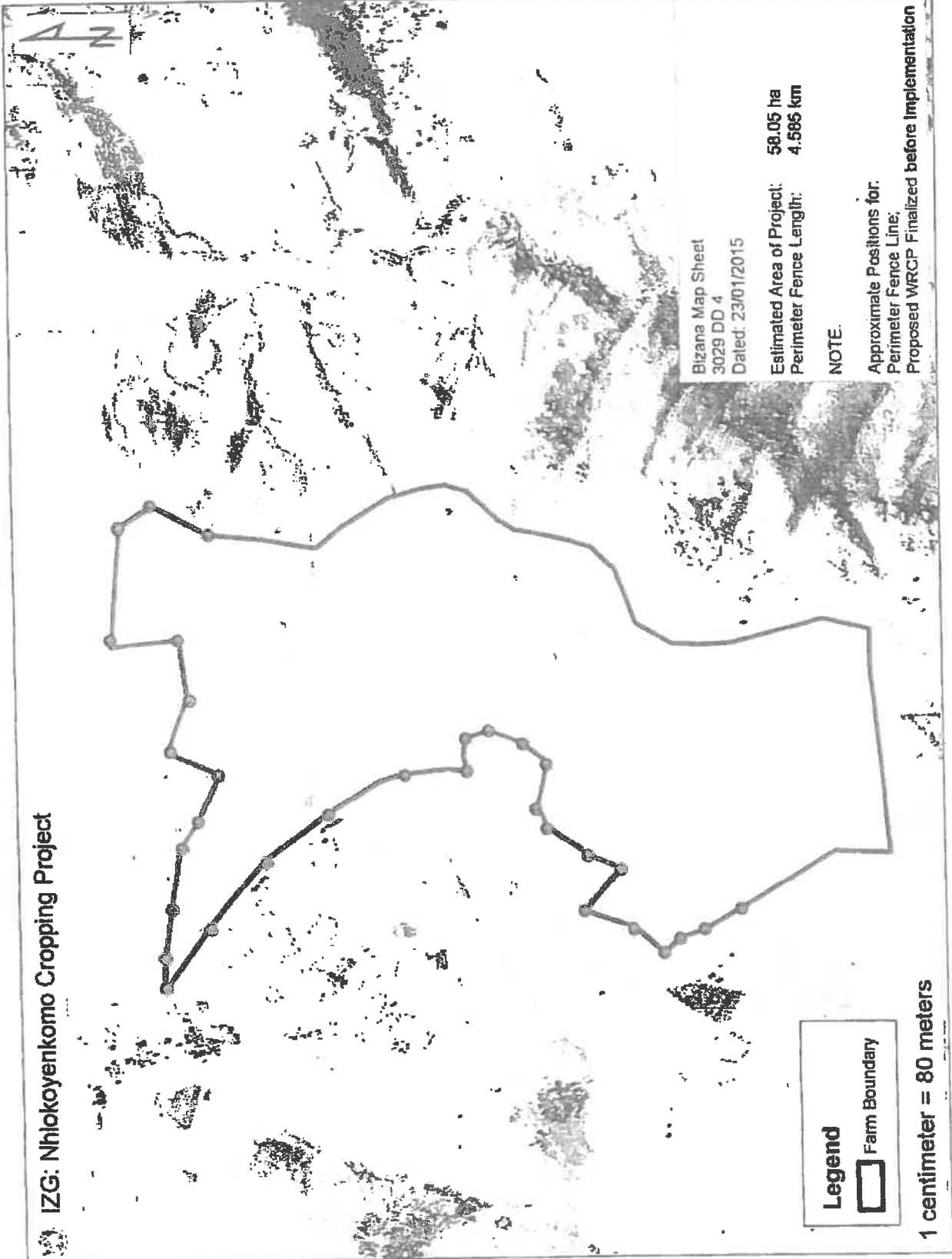

Bizana Map Sheet
3029 DD 4
Dated: 23/01/2015

Estimated Area of Project: 58.05 ha
Perimeter Fence Length: 4.586 km

NOTE:

Approximate Positions for
Perimeter Fence Line,
Proposed WRCP Finalized before Implementation

Legend
[Solid Line] Farm Boundary
[Line with Dots] Perimeter Fence Line

1 centimeter = 80 meters

NHLO KOYENKOMO FENCING

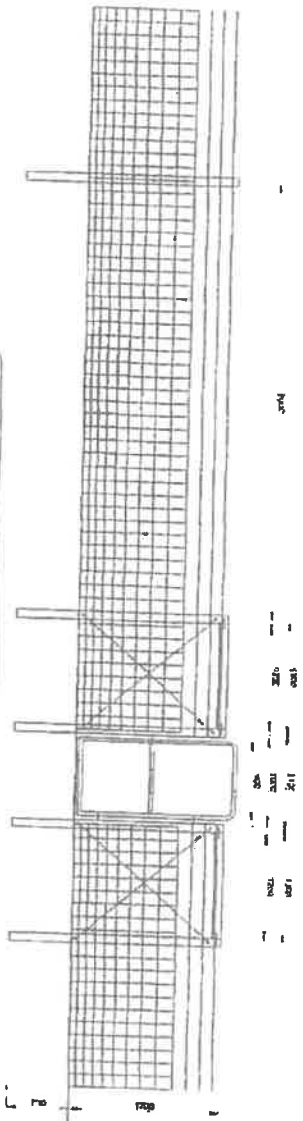

FENCE LINE WITH PEDESTRIAN GATE

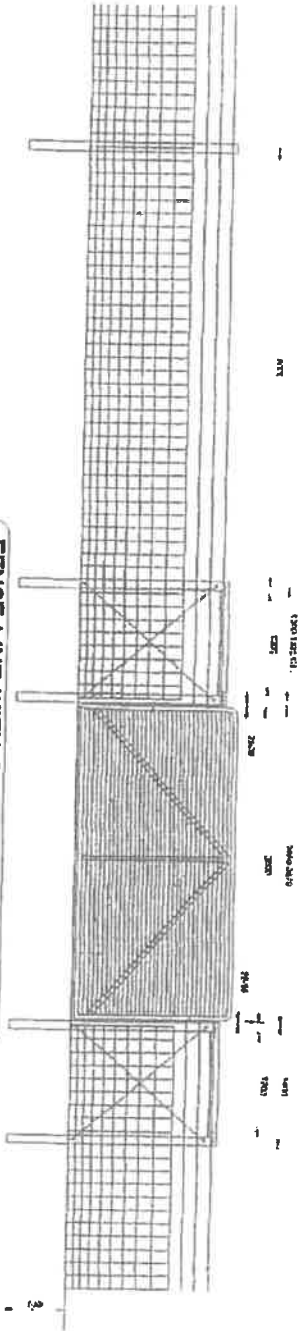

FENCE LINE WITH SINGLE VEHICLE GATE

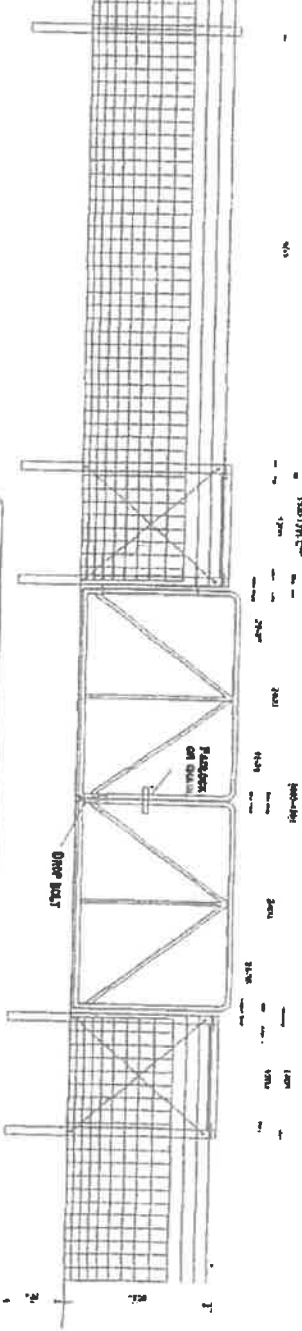

FENCE LINE WITH DOUBLE TRACTOR GATE

NOTES

- 1) All Posts Pressure Treated (CROCOD) (NOT PAINTED ON), 2.4M x 100 x 120MM SQUARE.
- 2) Fences above ground 1.2M vertical, vertical, 100mm above ground, horizontal, 100mm - 100mm, 100mm above ground, horizontal, 100mm - 100mm, 100mm above ground, horizontal, 100mm - 100mm.
- 3) Three strands of barbed wire along the fence with fence 150mm apart.
- 4) Barbed wire 150mm, 1.6M diameter, square, 150mm - 150mm.
- 5) The fence should be secured onto the horizontal posts and posts by means of 3.18 x 52 mm rivets.
- 6) The strakes are to be installed over the horizontal posts at a 45 degree angle. Posts, 5.0M apart, to be placed in holes 700mm deep and very well compacted with soil or tamped.
- 7) Strake posts require a 200mm x 100mm x 100mm/centric pin.
- 8) Posts are to be installed in holes 700mm deep and very well compacted with soil or tamped.
- 9) Posts are to be installed in holes 700mm deep and very well compacted with soil or tamped.
- 10) Posts are to be installed in holes 700mm deep and very well compacted with soil or tamped.
- 11) One for each end of each. Double end at 90 degrees angle at corner.
- 12) Additional posts as required, not every 100m.
- 13) All gates to be made with 50 x 100mm rectangular.
- 14) Use wire strakes for tensioning of strakes.
- 15) All gates to be made on 50mm pressure treated.

KENYA DEPARTMENT OF AGRICULTURE
ENVIRONMENTAL AFFAIRS &
RURAL DEVELOPMENT

ENGINEERING SERVICES
4 PRINCE AVENUE / P.O. BOX 20000
NAIROBI / KENYA / PHONE: 00254-20-300000 / FAX: 00254-20-300000

Drawn by: R. de Haer
Checked by: R. de Haer
Date: 18 October 2015

DRAWING REF.:
R000001217/01
SCALE 1:40 (AS)

SPECIFICATIONS HINGED JOINT
FENCING WITH GATES

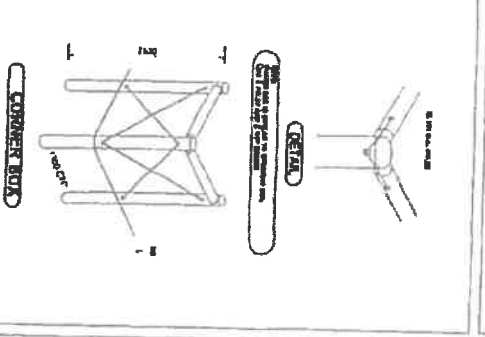

DECLARATION OF INTEREST

1. Any legal person, including persons employed by the state¹, or persons having a kinship with persons employed by the state, including a blood relationship, may make an offer or offers in terms of this invitation to bid (includes an advertised competitive bid, a limited bid, a proposal or written price quotation). In view of possible allegations of favouritism, should the resulting bid, or part thereof, be awarded to persons employed by the state, or to persons connected with or related to them, it is required that the bidder or his/her authorised representative declare his/her position in relation to the evaluating/adjudicating authority where-
 - the bidder is employed by the state; and/or
 - the legal person on whose behalf the bidding document is signed, has a relationship with persons/a person who are/is involved in the evaluation and or adjudication of the bid(s), or where it is known that such a relationship exists between the person or persons for or on whose behalf the declarant acts and persons who are involved with the evaluation and or adjudication of the bid.

 2. **In order to give effect to the above, the following questionnaire must be completed and submitted with the bid.**
 - 2.1 Full Name of bidder or his or her representative:
.....
 - 2.2 Identity Number:
.....
 - 2.3 Position occupied in the Company (director, trustee, shareholder², member):
.....
 - 2.4 Registration number of company, enterprise, close corporation, partnership agreement or trust:
.....
 - 2.5 Tax Reference Number:
.....
 - 2.6 VAT Registration Number:
.....
 - 2.6.1 The names of all directors / trustees / shareholders / members, their individual identity numbers, tax reference numbers and, if applicable, employee / PERSAL numbers must be indicated in paragraph 3 below.
-

1"State" means –

- (a) any national or provincial department, national or provincial public entity or constitutional institution within the meaning of the Public Finance Management Act, 1999 (Act No. 1 of 1999);
- (b) any municipality or municipal entity;
- (c) provincial legislature;
- (d) national Assembly or the national Council of provinces; or
- (e) Parliament.

2"Shareholder" means a person who owns shares in the company and is actively involved in the management of the enterprise or business and exercises control over the enterprise.

Please clearly indicate, with an 'X' only one box that is applicable to your business or firm

2.7 Are you or any person connected with the bidder presently employed by the state?

YES	NO
-----	----

2.7.1 If so, furnish the following particulars:

Name of person / director / trustee / shareholder/member:

.....

Name of state institution at which you or the person connected to the bidder is employed

.....

Position occupied in the state institution:

.....

Any other particulars:

.....

2.7.2 If you are presently employed by the state, did you obtain

YES	NO
-----	----

the appropriate authority to undertake remunerative work outside employment in the public sector?

If yes, did you attach proof of such authority to the bid document?

YES	NO
-----	----

(Note: Failure to submit proof of such authority, where applicable, may result in the disqualification of the bid.)

2.7.2.1 If no, furnish reasons for non-submission of such proof:

.....

.....

2.8 Did you or your spouse, or any of the company's directors / trustees / shareholders / members or their spouses conduct business with the state in the previous twelve months?

YES	NO
-----	----

2.8.1 If so, furnish particulars:

.....

.....

2.9 Do you, or any person connected with the bidder, have any relationship (family, friend, other) with a person employed by the state and who may be involved with the evaluation and or adjudication of this bid?

YES	NO
-----	----

2.9.1 If so, furnish particulars.

.....

.....

2.10 Are you, or any person connected with the bidder, aware of any relationship (family, friend, other) between any other bidder and any person employed by the state who may be involved with the evaluation and or adjudication of this bid?

YES	NO
-----	----

2.10.1 If so, furnish particulars.

.....

.....

2.11 Do you or any of the directors / trustees / shareholders / members of the company have any interest in any other related companies whether or not they are bidding for this contract?

YES	NO
-----	----

2.11.1 If so, furnish particulars:

.....

.....

3 Full details of directors / trustees / members / shareholders.

Full Name	Identity Number	Personal Income Tax Reference Number	State Employee Number / Persal Number

4 DECLARATION

I, THE UNDERSIGNED (NAME).....

CERTIFY THAT THE INFORMATION FURNISHED IN PARAGRAPHS 2 and 3 ABOVE IS CORRECT.

I ACCEPT THAT THE STATE MAY REJECT THE BID OR ACT AGAINST ME SHOULD THIS DECLARATION PROVE TO BE FALSE.

.....
Name of bidder

.....
Position

.....
Signature

.....
Date

CERTIFICATE OF INDEPENDENT BID DETERMINATION

- 1 This Standard Bidding Document (SBD) must form part of all bids¹ invited.
- 2 Section 4 (1) (b) (iii) of the Competition Act No. 89 of 1998, as amended, prohibits an agreement between, or concerted practice by, firms, or a decision by an association of firms, if it is between parties in a horizontal relationship and if it involves collusive bidding (or bid rigging).² Collusive bidding is a *per se* prohibition meaning that it cannot be justified under any grounds.
- 3 Treasury Regulation 16A9 prescribes that accounting officers and accounting authorities must take all reasonable steps to prevent abuse of the supply chain management system and authorizes accounting officers and accounting authorities to:
 - a. disregard the bid of any bidder if that bidder, or any of its directors have abused the institution's supply chain management system and or committed fraud or any other improper conduct in relation to such system.
 - b. cancel a contract awarded to a supplier of goods and services if the supplier committed any corrupt or fraudulent act during the bidding process or the execution of that contract.
- 4 This SBD serves as a certificate of declaration that would be used by institutions to ensure that, when bids are considered, reasonable steps are taken to prevent any form of bid-rigging.
- 5 In order to give effect to the above, the attached Certificate of Bid Determination (SBD 9) must be completed and submitted with the bid:

¹ Includes price quotations, advertised competitive bids, limited bids and proposals.

² Bid rigging (or collusive bidding) occurs when businesses, that would otherwise be expected to compete, secretly conspire to raise prices or lower the quality of goods and / or services for purchasers who wish to acquire goods and / or services through a bidding process. Bid rigging is, therefore, an agreement between competitors not to compete.

CERTIFICATE OF INDEPENDENT BID DETERMINATION

I, the undersigned, in submitting the accompanying bid:

(Bid Number and Description)

in response to the invitation for the bid made by:

(Name of Institution)

do hereby make the following statements that I certify to be true and complete in every respect:

I certify, on behalf of _____ that:
(Name of Bidder)

1. I have read and I understand the contents of this Certificate;
2. I understand that the accompanying bid will be disqualified if this Certificate is found not to be true and complete in every respect;
3. I am authorized by the bidder to sign this Certificate, and to submit the accompanying bid, on behalf of the bidder;
4. Each person whose signature appears on the accompanying bid has been authorized by the bidder to determine the terms of, and to sign the bid, on behalf of the bidder;
5. For the purposes of this Certificate and the accompanying bid, I understand that the word "competitor" shall include any individual or organization, other than the bidder, whether or not affiliated with the bidder, who:
 - (a) has been requested to submit a bid in response to this bid invitation;
 - (b) could potentially submit a bid in response to this bid invitation, based on their qualifications, abilities or experience; and
 - (c) provides the same goods and services as the bidder and/or is in the same line of business as the bidder
6. The bidder has arrived at the accompanying bid independently from, and without consultation, communication, agreement or arrangement with any competitor. However communication between partners in a joint venture or consortium³ will not be construed as collusive bidding.

7. In particular, without limiting the generality of paragraphs 6 above, there has been no consultation, communication, agreement or arrangement with any competitor regarding:
- (a) prices;
 - (b) geographical area where product or service will be rendered (market allocation)
 - (c) methods, factors or formulas used to calculate prices;
 - (d) the intention or decision to submit or not to submit, a bid;
 - (e) the submission of a bid which does not meet the specifications and conditions of the bid; or
 - (f) bidding with the intention not to win the bid.
8. In addition, there have been no consultations, communications, agreements or arrangements with any competitor regarding the quality, quantity, specifications and conditions or delivery particulars of the products or services to which this bid invitation relates.
9. The terms of the accompanying bid have not been, and will not be, disclosed by the bidder, directly or indirectly, to any competitor, prior to the date and time of the official bid opening or of the awarding of the contract.
10. I am aware that, in addition and without prejudice to any other remedy provided to combat any restrictive practices related to bids and contracts, bids that are suspicious will be reported to the Competition Commission for investigation and possible imposition of administrative penalties in terms of section 59 of the Competition Act No 89 of 1998 and or may be reported to the National Prosecuting Authority (NPA) for criminal investigation and or may be restricted from conducting business with the public sector for a period not exceeding ten (10) years in terms of the Prevention and Combating of Corrupt Activities Act No 12 of 2004 or any other applicable legislation.

.....
Signature

.....
Date

.....
Position

.....
Name of Bidder