



**KWAZULU-NATAL PROVINCE**  
**AGRICULTURE AND RURAL DEVELOPMENT**  
 REPUBLIC OF SOUTH AFRICA

**INVITATION OF QUOTATION FROM R1 - R1 MILLION**

THIS FORM SHOULD BE COMPLETED IN DETAIL AND SHOULD BE ACCOMPANY **A VALID BBBEE CERTIFICATE/SWORN AFFIDAVIT /CSD REPORT**

QUOTATION NUMBER: <b>R/S/2425/111</b>	VALIDITY PERIOD OF QUOTATION..... Days (To be completed by the Supplier)
CLOSING DATE: <b>26/04/2024</b>	<b>CLOSING TIME: 11H00</b>
DESCRIPTION(SPECIFICATION/S) OF ITEMS/ SERVICE REQUIRED:  <b>SPARE PARTS REQUIRED FOR FALCON FLAIL MOWER.</b>  (See attached spec)	COMPANY NAME: _____ TEL NO: _____ FAX NO: _____ CONTACT PERSON: _____  <b>CSD REG NUMBER MAAA.....</b>
DOES OFFER COMPLY WITH SPECIFICATION?	YES/NO (DELETE WHICH EVER IS NOT APPLICABLE)
DOES ARTICLE COMPLY WITH SABS SPECIFICATION? HAS IT BEEN INSPECTED BY SABS?	YES/NO YES/NO (DELETE WHICH EVER IS NOT APPLICABLE)
DELIVERY PERIOD AFTER INITIAL ORDER?	
IS THE PRICE FIRM	
WHERE ARE THE STOCK HELD? (PHYSICAL ADDRESS , PLEASE)	
QUOTATION PRICE INCLUDING VAT (VAT TO BE ADDED BY REGISTERED VAT VENDORS ONLY)	TOTAL: R .....
COMPANY OFFICIAL STAMP (COMPULSORY)	..... SIGNATURE OF BIDDER  ..... DATE
<b>Quotation to be returned to: Ntuthuko Hlengwa</b> <b>Department of Agriculture &amp; Rural Development:</b>  <a href="mailto:Ntuthuko.Hlengwa@kzndard.gov.za">Ntuthuko.Hlengwa@kzndard.gov.za</a>  <b>Tel. No: 033 343 8367</b>	
NB: DOCUMENT MUST BE COMPLETED IN FULL THIS QUOTATION COVER PAGE MUST BE COMPLETED AND RETURNED WITH ALL YOUR SUPPORTING DOCUMENTS.	

**FOR ENQUIRY ONLY**

**END-USER NAME** : A.J.Kent.  
**CELLPHONE NUMBER** : 033 355 9192  
**E-MAIL ADDRESS** : Alistair.Kent@kzndard.gov.za  
**PROPOSED DELIVERY DATE** : 28<sup>th</sup> June 2024  
**DELIVERY ADDRESS** : Cedara Farm Services  
**LOCAL MUNICIPALITY** : Umngeni  
**DISTRICT** : Umgungundlovu

LINE NO.	DESCRIPTION OR SPECIFICATION OF ITEM (Please be very specific and clear)	REQUIRED QUANTITY	UNIT PRICE EXCL. VAT		TOTAL PRICE	
			R	C	R	C
	<b>Supply and deliver genuine Falcon flail spare parts to Cedara Farm Services</b> <b>Only Genuine spare parts will be accepted</b>					
	<b>The following parts are required for a Falcon flail mower model F210</b>					
1	<b>Carriage bolt M12</b> Part number: M712040	12				
2	<b>Nyloc nuts M12</b> Part number: M61209	12				
3	<b>Seal</b> Part number: M5706	2				
4	<b>Seal</b> Part number: 5707	2				
5	<b>Circlip</b> Part number: S11276	4				
6	<b>Bush 60x73x80-M70supamide</b> Part number: H5663	1				
7	<b>Bush 60x73x125-M70supamide</b> Part number: H5664	2				
8	<b>Spacer</b> Part number: H 5671	1				
9	<b>Washer flat M12</b> Part number: M 81202	20				
10	<b>Bearing UCFL207</b> Part number M0461	2				

	* LABOUR (IF APPLICABLE)		
	*DELIVERY (IF APPLICABLE)		
		TOTAL	
	*ONLY APPLICABLE TO VAT REGISTERED SUPPLIERS	15% VAT	
		TOTAL PRICE	
<b>CIDB Grading (IF APPLICABLE):</b>			

COMPANY NAME : \_\_\_\_\_

CSD NUMBER : \_\_\_\_\_

ADDRESS : \_\_\_\_\_

CONTACT PERSON : \_\_\_\_\_

CONTACT NUMBER : \_\_\_\_\_

\*VAT Registration No. (Supplier) -----

PRICES ARE VALID FOR      DAYS      **Mark one Box (X)**

30	60	90	120
----	----	----	-----

SIGNATURE.....

DATE.....

**Flail Cutter: Main Body**  
**1 = F150 (A0102) 2 = F170 (A0103) 3 = F210 (A0105) 4 = F230 (A0106)**

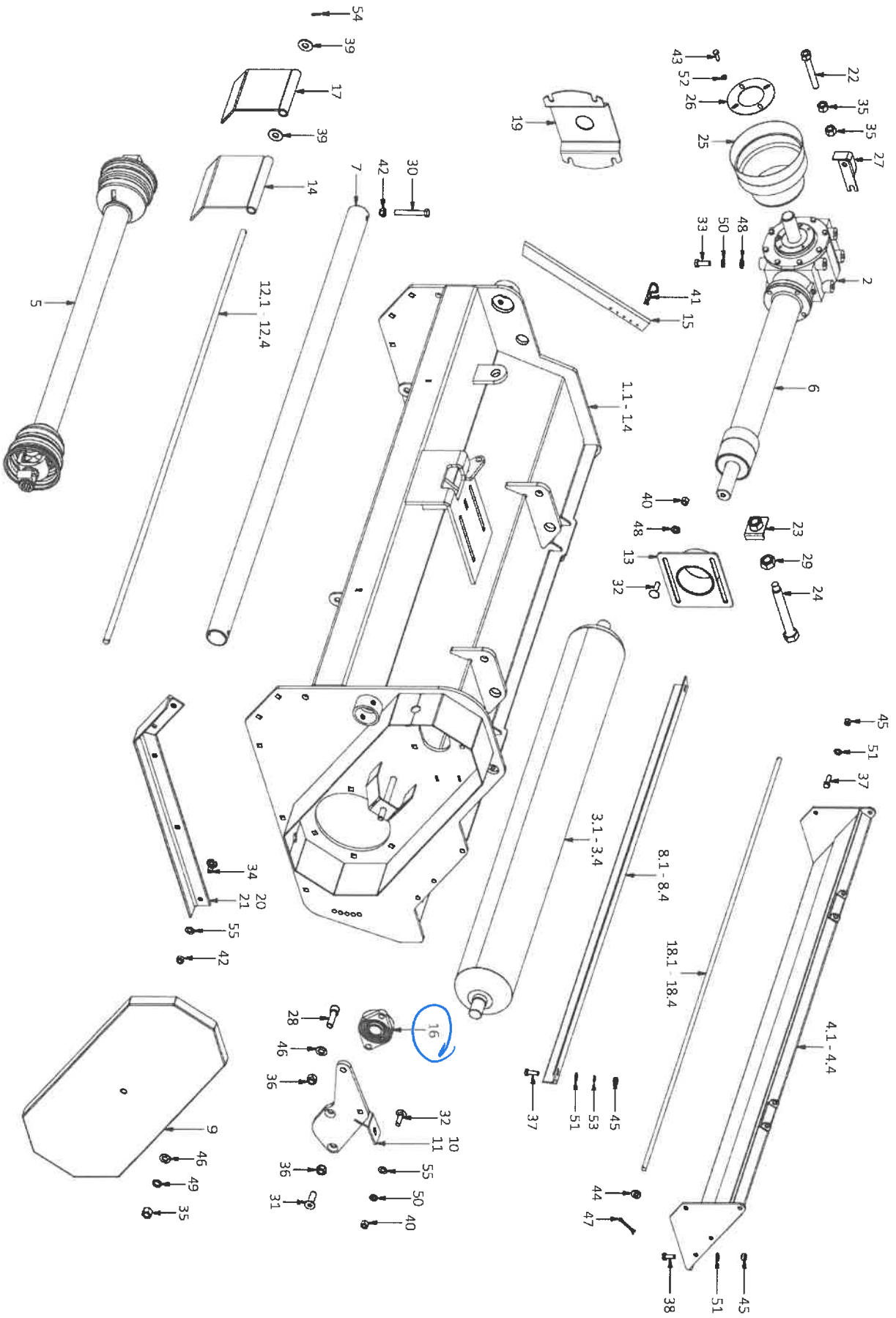

**Flail Cutter: Main Body**  
**1 = F150 (A0102) 2 = F170 (A0103) 3 = F210 (A0105) 4 = F230 (A0106)**

Item	Part No.	Description	1	2	3	4	Item	Part No.	Description	1	2	3	4
1.1	H5602	Deck 1500	1				23	H5661	Nut Captured	1	1	1	1
1.2	H5603	Deck 1700		1			24	H5662	Leadscrew M24x190	1	1	1	1
1.3	H5605	Deck 2100				1	25	M1141	PTO Counter-cone Rnd	1	1	1	1
1.4	H5606	Deck 2300				1	26	M5579	Plate 4-M8@PCD105 2.0 MS PLB0	1	1	1	1
2	M5650	Gearbox T311L1 Corner	1	1	1	1	27	H5665	Bracket Adjust	1	1	1	1
3.1	H5622	Roller 1500 D165.0	1				28	M51650	Hexagon Socket Head Cap Screw	2	2	2	2
3.2	H5623	Roller 1700 D165.0		1			29	M32418	Nut M124	1	1	1	1
3.3	H5625	Roller 2100 D165.0				1	30	M41290	Bolt M12x90HT	4	4	4	4
3.4	H5626	Roller 2300 D165.0				1	31	M51645	Cap screw M16 x 45 CSK	4	4	4	4
4.1	H5632	Cover Discharge 1500	1				32	N712040	Carriage bolt M12x40	6	6	6	6
4.2	H5633	Cover Discharge 1700		1			33	M41235	Bolt M12x35HT	5	5	5	5
4.3	H5635	Cover Discharge 2100				1	34	N712030	Carriage bolt M12x30	10	10	10	10
4.4	H5636	Cover Discharge 2300				1	35	M11640	Bolt + Nut M16x40HT	3	3	3	3
5	T601010CE112112	PTO shaft T60 1010 112 112	1	1	1	1	36	M61616	Nut Nylon M16	6	6	6	6
6	M5651	Extension 780mm Corner	1	1	1	1	37	M41030	Bolt M10x30HT	6	6	6	6
7	H5620	Rail Sliding Lower	1	1	1	1	38	M41025	Bolt M10x25HT	4	4	4	4
8.1	H5692	Scrapers 1500	1				39	M81603	Washer M16x40x3	9	10	12	13
8.2	H5693	Scrapers 1700		1			40	M31209	Nut M12	6	6	6	6
8.3	H5695	Scrapers 2100				1	41	M5235	R-clip 4mm	14	16	20	22
8.4	H5696	Scrapers 2300				1	42	M61209	Nut Nylon M12	12	12	12	12
9	H5649	Cover Belt drive	1	1	1	1	43	M40825	Bolt M8x25HT	4	4	4	4
10	H5656	Bearing carrier L Adjust	1	1	1	1	44	M5723	Washer 13x25x5 5.0	2	2	2	2
11	H5657	Bearing carrier R Adjust	1	1	1	1	45	M31007	Nut M10	10	10	10	10
12.1	H5684	Pin 1500 D16.0	1				46	M81602	Washer Flat M16x40x2	3	3	3	3
12.2	H5685	Pin 1700 D16.0		1			47	M1399	Split pin B4x60	2	2	2	2
12.3	H5687	Pin 2100 D16.0				1	48	M8577	Washer profiled 12.5x30x4.5	8	8	8	8
12.4	H5688	Pin 2300 D16.0				1	49	M91604	Washer Spring M16	1	1	1	1
13	H5658	Baseplate Tensioner Ext shaft	1	1	1	1	50	M91213	Washer Spring M12	6	6	6	6
14	H5653	Flap Safety Main	6	7	9	10	51	M81002	Washer Flat M10	10	10	10	10
15	H5655	Rake Adjust 40x12x400	14	16	20	22	52	M80803	Washer Flat M8	4	4	4	4
16	M0461	Bearing UCH1207	2	2	2	2	53	M91002	Washer Spring M10	2	2	2	2
17	H5654	Flap Safety End	2	2	2	2	54	M5243	Roll pin 4x25	2	2	2	2
18.1	H5642	Pin 1500 D12.0	1				55	M81202	Washer Flat M12	20	20	20	20
18.2	H5643	Pin 1700 D12.0		1									
18.3	H5645	Pin 2100 D12.0				1							
18.4	H5646	Pin 2300 D12.0				1							
19	M5799	Guard	1	1	1	1							
20	H5647	Skid runner L	1	1	1	1							
21	H5648	Skid runner R	1	1	1	1							
22	H5666	Leadscrew M16x110	1	1	1	1							

**Flail Cutter: Cutting Gear Assembly**  
**1 = F150 (A0102) 2 = F170 (A0103) 3 = F210 (A0105) 4 = F230 (A0106)**

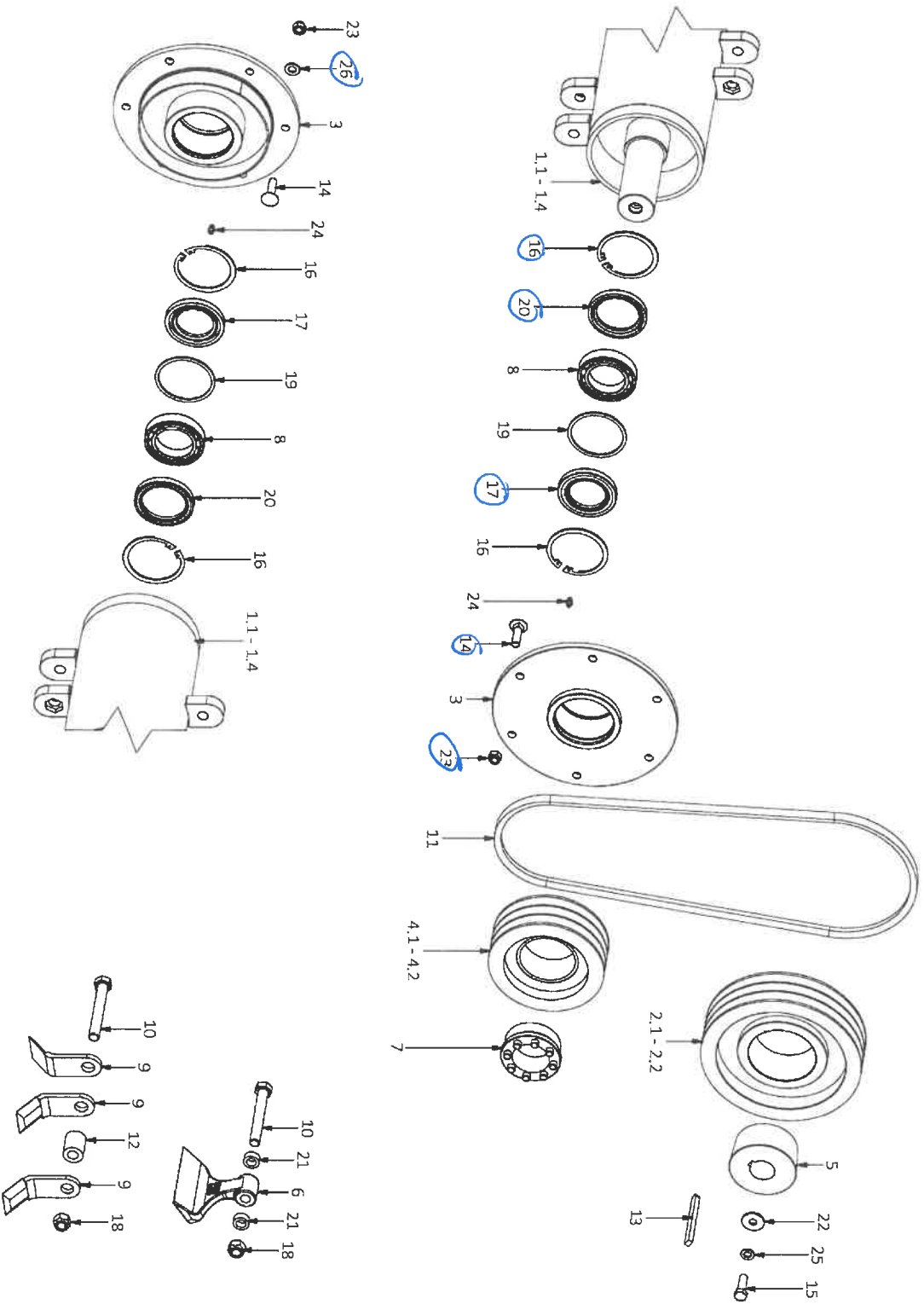

**Flail Cutter: Cutting Gear Assembly**  
**1 = F150 (A0102) 2 = F170 (A0103) 3 = F210 (A0105) 4 = F230 (A0106)**

Item	Part No.	Description	Item				Part No.	Description	Item				
			1	2	3	4			1	2	3	4	
1.1	H5612	Rotor 1500 x14 mount	1										
1.2	H5613	Rotor 1700 x16 mount		1									
1.3	H5615	Rotor 2100 x20 mount			1								
1.4	H5616	Rotor 2300 x22 mount				1							
2.1	M5718	Pulley SPB 250-3V TL3020-40	1	1									
2.2	M5719	Pulley SPB 250-4V TL3020-40			1	1							
3	H5668	Bearing carrier D95-PCD258	2	2	2	2							
4.1	M5716	Pulley SPB 180-3V FLK133-60x90	1	1									
4.2	M5717	Pulley SPB 180-4V FLK133-60x90			1	1							
5	M5702	Taper-lock bush 3020-40	1	1	1	1							
6	M5735	Hammer Flail MANO801N08C 120x110x16	14	16	20	22							
7	M5703	Locking element FLK133-60x90	1	1	1	1							
8	M5705	Bearing 6012	2	2	2	2							
9	M5730	Blade Flail TNO801N08C 8x40	42	48	60	66							
10	M616110	Bolt M16x110-10.9	14	16	20	22							
11	M5715	Belt SPB-1600	3	3	4	4							
12	H5675	Bush 17x32x36	14	16	20	22							
13	M5704	Key 12x8x100	1	1	1	1							
14	M712040	Carriage bolt M12x40	12	12	12	12							
15	M41235	Bolt M12x35HT	1	1	1	1							
16	M5708	Circlip Int INT0950	4	4	4	4							
17	M5707	Seal Radial lip 60x95x10	2	2	2	2							
18	M61616	Nut Nyloc M16	14	16	20	22							
19	H5671	Spacer 85x95x3	2	2	2	2							
20	M5706	Seal Radial lip 70x95x10	2	2	2	2							
21	H71610	Bush 17x32x10	28	32	40	44							
22	M8537	Washer 12.5x36x3	1	1	1	1							
23	M61209	Nut Nyloc M12	12	12	12	12							
24	M10039	Grease nipple 1/8"	2	2	2	2							
25	M91213	Washer Spring M12	1	1	1	1							
26	M81202	Washer Flat M12	4	4	4	4							

**Flail Cutter: Hitch Frame Assembly**  
**1 = F150 (A0102) 2 = F170 (A0103) 3 = F210 (A0105) 4 = F230 (A0106)**

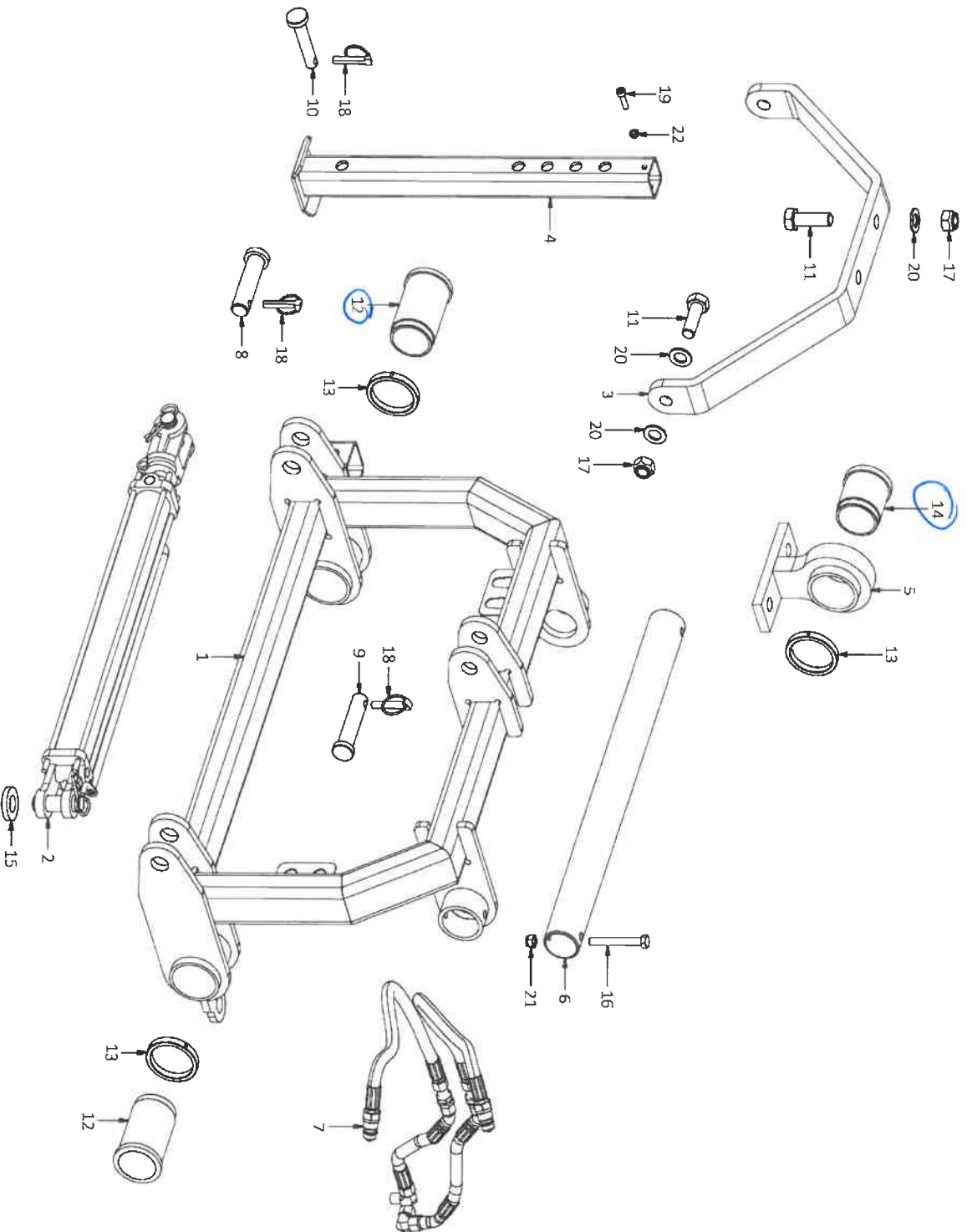







**SBD1**

**PART A**

**INVITATION TO BID**

<b>YOU ARE HEREBY INVITED TO BID FOR REQUIREMENTS OF THE (NAME OF DEPARTMENT/ PUBLIC ENTITY)</b>					
BID NUMBER:	R/S/2425/111	CLOSING DATE:	26/04/2024	CLOSING TIME:	11H00
DESCRIPTION					
<b>BID RESPONSE DOCUMENTS MAY BE DEPOSITED IN THE BID BOX SITUATED AT (STREET ADDRESS)</b>					
<b>BIDDING PROCEDURE ENQUIRIES MAY BE DIRECTED TO</b>			<b>TECHNICAL ENQUIRIES MAY BE DIRECTED TO:</b>		
CONTACT PERSON	NTUTHUKO HLENGWA		CONTACT PERSON	AJ KENT	
TELEPHONE NUMBER	033 343 8367		TELEPHONE NUMBER	033 355 9192	
FACSIMILE NUMBER	N/A		FACSIMILE NUMBER	N/A	
E-MAIL ADDRESS	Ntuthuko.Hlengwa@kzndard.gov.za		E-MAIL ADDRESS		
<b>SUPPLIER INFORMATION</b>					
NAME OF BIDDER					
POSTAL ADDRESS					
STREET ADDRESS					
TELEPHONE NUMBER	CODE		NUMBER		
CELLPHONE NUMBER					
FACSIMILE NUMBER	CODE		NUMBER		
E-MAIL ADDRESS					
VAT REGISTRATION NUMBER					
SUPPLIER COMPLIANCE STATUS	TAX COMPLIANCE SYSTEM PIN:		OR	CENTRAL SUPPLIER DATABASE No:	MAAA
ARE YOU THE ACCREDITED REPRESENTATIVE IN SOUTH AFRICA FOR THE GOODS /SERVICES /WORKS OFFERED?	<input type="checkbox"/> Yes <input type="checkbox"/> No [IF YES ENCLOSE PROOF]		ARE YOU A FOREIGN BASED SUPPLIER FOR THE GOODS /SERVICES /WORKS OFFERED?	<input type="checkbox"/> Yes <input type="checkbox"/> No [IF YES, ANSWER THE QUESTIONNAIRE BELOW]	
<b>QUESTIONNAIRE TO BIDDING FOREIGN SUPPLIERS</b>					
IS THE ENTITY A RESIDENT OF THE REPUBLIC OF SOUTH AFRICA (RSA)?				<input type="checkbox"/> YES <input type="checkbox"/> NO	
DOES THE ENTITY HAVE A BRANCH IN THE RSA?				<input type="checkbox"/> YES <input type="checkbox"/> NO	
DOES THE ENTITY HAVE A PERMANENT ESTABLISHMENT IN THE RSA?				<input type="checkbox"/> YES <input type="checkbox"/> NO	
DOES THE ENTITY HAVE ANY SOURCE OF INCOME IN THE RSA?				<input type="checkbox"/> YES <input type="checkbox"/> NO	
IS THE ENTITY LIABLE IN THE RSA FOR ANY FORM OF TAXATION?				<input type="checkbox"/> YES <input type="checkbox"/> NO	
<b>IF THE ANSWER IS "NO" TO ALL OF THE ABOVE, THEN IT IS NOT A REQUIREMENT TO REGISTER FOR A TAX COMPLIANCE STATUS SYSTEM PIN CODE FROM THE SOUTH AFRICAN REVENUE SERVICE (SARS) AND IF NOT REGISTER AS PER 2.3 BELOW.</b>					

**PART B  
TERMS AND CONDITIONS FOR BIDDING**

<b>1.</b>	<b>BID SUBMISSION:</b>
1.1.	BIDS MUST BE DELIVERED BY THE STIPULATED TIME TO THE CORRECT ADDRESS. LATE BIDS WILL NOT BE ACCEPTED FOR CONSIDERATION.
1.2.	ALL BIDS MUST BE SUBMITTED ON THE OFFICIAL FORMS PROVIDED—(NOT TO BE RE-TYPED) OR IN THE MANNER PRESCRIBED IN THE BID DOCUMENT.
1.3.	THIS BID IS SUBJECT TO THE PREFERENTIAL PROCUREMENT POLICY FRAMEWORK ACT, 2000 AND THE PREFERENTIAL PROCUREMENT REGULATIONS, 2017, THE GENERAL CONDITIONS OF CONTRACT (GCC) AND, IF APPLICABLE, ANY OTHER SPECIAL CONDITIONS OF CONTRACT.
1.4.	THE SUCCESSFUL BIDDER WILL BE REQUIRED TO FILL IN AND SIGN A WRITTEN CONTRACT FORM (SBD7).
<b>2.</b>	<b>TAX COMPLIANCE REQUIREMENTS</b>
2.1	BIDDERS MUST ENSURE COMPLIANCE WITH THEIR TAX OBLIGATIONS.
2.2	BIDDERS ARE REQUIRED TO SUBMIT THEIR UNIQUE PERSONAL IDENTIFICATION NUMBER (PIN) ISSUED BY SARS TO ENABLE THE ORGAN OF STATE TO VERIFY THE TAXPAYER'S PROFILE AND TAX STATUS.
2.3	APPLICATION FOR TAX COMPLIANCE STATUS (TCS) PIN MAY BE MADE VIA E-FILING THROUGH THE SARS WEBSITE WWW.SARS.GOV.ZA.
2.4	BIDDERS MAY ALSO SUBMIT A PRINTED TCS CERTIFICATE TOGETHER WITH THE BID.
2.5	IN BIDS WHERE CONSORTIA / JOINT VENTURES / SUB-CONTRACTORS ARE INVOLVED, EACH PARTY MUST SUBMIT A SEPARATE TCS CERTIFICATE / PIN / CSD NUMBER.
2.6	WHERE NO TCS PIN IS AVAILABLE BUT THE BIDDER IS REGISTERED ON THE CENTRAL SUPPLIER DATABASE (CSD), A CSD NUMBER MUST BE PROVIDED.
2.7	NO BIDS WILL BE CONSIDERED FROM PERSONS IN THE SERVICE OF THE STATE, COMPANIES WITH DIRECTORS WHO ARE PERSONS IN THE SERVICE OF THE STATE, OR CLOSE CORPORATIONS WITH MEMBERS PERSONS IN THE SERVICE OF THE STATE.

**NB: FAILURE TO PROVIDE / OR COMPLY WITH ANY OF THE ABOVE PARTICULARS MAY RENDER THE BID INVALID.**

SIGNATURE OF BIDDER: .....

CAPACITY UNDER WHICH THIS BID IS SIGNED: .....  
(Proof of authority must be submitted e.g. company resolution)

DATE: .....

**BIDDER'S DISCLOSURE**

**1. PURPOSE OF THE FORM**

Any person (natural or juristic) may make an offer or offers in terms of this invitation to bid. In line with the principles of transparency, accountability, impartiality, and ethics as enshrined in the Constitution of the Republic of South Africa and further expressed in various pieces of legislation, it is required for the bidder to make this declaration in respect of the details required hereunder.

Where a person/s are listed in the Register for Tender Defaulters and / or the List of Restricted Suppliers, that person will automatically be disqualified from the bid process.

**2. Bidder's declaration**

2.1 Is the bidder, or any of its directors / trustees / shareholders / members / partners or any person having a controlling interest<sup>1</sup> in the enterprise, employed by the state? **YES/NO**

2.1.1 If so, furnish particulars of the names, individual identity numbers, and, if applicable, state employee numbers of sole proprietor/ directors / trustees / shareholders / members/ partners or any person having a controlling interest in the enterprise, in table below.

Full Name	Identity Number	Name of State institution

2.2 Do you, or any person connected with the bidder, have a relationship with any person who is employed by the procuring institution? **YES/NO**

2.2.1 If so, furnish particulars:  
.....  
.....

2.3 Does the bidder or any of its directors / trustees / shareholders / members / partners or any person having a controlling interest in the enterprise have any interest in any other related enterprise whether or not they are bidding for this contract? **YES/NO**

2.3.1 If so, furnish particulars:  
.....  
.....

---

<sup>1</sup> the power, by one person or a group of persons holding the majority of the equity of an enterprise, alternatively, the person/s having the deciding vote or power to influence or to direct the course and decisions of the enterprise.

**3 DECLARATION**

I, the undersigned, (name)..... in submitting the accompanying bid, do hereby make the following statements that I certify to be true and complete in every respect:

- 3.1 I have read and I understand the contents of this disclosure;
- 3.2 I understand that the accompanying bid will be disqualified if this disclosure is found not to be true and complete in every respect;
- 3.3 The bidder has arrived at the accompanying bid independently from, and without consultation, communication, agreement or arrangement with any competitor. However, communication between partners in a joint venture or consortium<sup>2</sup> will not be construed as collusive bidding.
- 3.4 In addition, there have been no consultations, communications, agreements or arrangements with any competitor regarding the quality, quantity, specifications, prices, including methods, factors or formulas used to calculate prices, market allocation, the intention or decision to submit or not to submit the bid, bidding with the intention not to win the bid and conditions or delivery particulars of the products or services to which this bid invitation relates.
- 3.4 The terms of the accompanying bid have not been, and will not be, disclosed by the bidder, directly or indirectly, to any competitor, prior to the date and time of the official bid opening or of the awarding of the contract.
- 3.5 There have been no consultations, communications, agreements or arrangements made by the bidder with any official of the procuring institution in relation to this procurement process prior to and during the bidding process except to provide clarification on the bid submitted where so required by the institution; and the bidder was not involved in the drafting of the specifications or terms of reference for this bid.
- 3.6 I am aware that, in addition and without prejudice to any other remedy provided to combat any restrictive practices related to bids and contracts, bids that are suspicious will be reported to the Competition Commission for investigation and possible imposition of administrative penalties in terms of section 59 of the Competition Act No 89 of 1998 and or may be reported to the National Prosecuting Authority (NPA) for criminal investigation and or may be restricted from conducting business with the public sector for a period not exceeding ten (10) years in terms of the Prevention and Combating of Corrupt Activities Act No 12 of 2004 or any other applicable legislation.

I CERTIFY THAT THE INFORMATION FURNISHED IN PARAGRAPHS 1, 2 and 3 ABOVE IS CORRECT.

I ACCEPT THAT THE STATE MAY REJECT THE BID OR ACT AGAINST ME IN TERMS OF PARAGRAPH 6 OF PFMA SCM INSTRUCTION 03 OF 2021/22 ON PREVENTING AND COMBATING ABUSE IN THE SUPPLY CHAIN MANAGEMENT SYSTEM SHOULD THIS DECLARATION PROVE TO BE FALSE.

.....	.....
Signature	Date
.....	.....
Position	Name of bid

<sup>2</sup> Joint venture or Consortium means an association of persons for the purpose of combining their expertise, property, capital, efforts, skill and knowledge in an activity for the execution of a contract.

## PREFERENCE POINTS CLAIM FORM IN TERMS OF THE PREFERENTIAL PROCUREMENT REGULATIONS 2022

This preference form must form part of all tenders invited. It contains general information and serves as a claim form for preference points for specific goals.

**NB: BEFORE COMPLETING THIS FORM, TENDERERS MUST STUDY THE GENERAL CONDITIONS, DEFINITIONS AND DIRECTIVES APPLICABLE IN RESPECT OF THE TENDER AND PREFERENTIAL PROCUREMENT REGULATIONS, 2022**

### 1. GENERAL CONDITIONS

1.1 The following preference point systems are applicable to invitations to tender:

- the 80/20 system for requirements with a Rand value of up to R50 000 000 (all applicable taxes included); and
- the 90/10 system for requirements with a Rand value above R50 000 000 (all applicable taxes included).

1.2 **To be completed by the organ of state**

*(delete whichever is not applicable for this tender).*

- a) The applicable preference point system for this tender is the 90/10 preference point system.
- b) The applicable preference point system for this tender is the 80/20 preference point system.
- c) Either the 90/10 or 80/20 preference point system will be applicable in this tender. The lowest/ highest acceptable tender will be used to determine the accurate system once tenders are received.

1.3 Points for this tender (even in the case of a tender for income-generating contracts) shall be awarded for:

- (a) Price; and
- (b) Specific Goals.

1.4 **To be completed by the organ of state:**

The maximum points for this tender are allocated as follows:

	POINTS
<b>PRICE</b>	<b>80</b>
<b>SPECIFIC GOALS</b>	<b>20</b>
<b>Total points for Price and SPECIFIC GOALS</b>	<b>100</b>

- 1.5 Failure on the part of a tenderer to submit proof or documentation required in terms of this tender to claim points for specific goals with the tender, will be interpreted to mean that preference points for specific goals are not claimed.
- 1.6 The organ of state reserves the right to require of a tenderer, either before a tender is adjudicated or at any time subsequently, to substantiate any claim in regard to preferences, in any manner required by the organ of state.

## 2. DEFINITIONS

- (a) **“tender”** means a written offer in the form determined by an organ of state in response to an invitation to provide goods or services through price quotations, competitive tendering process or any other method envisaged in legislation;
- (b) **“price”** means an amount of money tendered for goods or services, and includes all applicable taxes less all unconditional discounts;
- (c) **“rand value”** means the total estimated value of a contract in Rand, calculated at the time of bid invitation, and includes all applicable taxes;
- (d) **“tender for income-generating contracts”** means a written offer in the form determined by an organ of state in response to an invitation for the origination of income-generating contracts through any method envisaged in legislation that will result in a legal agreement between the organ of state and a third party that produces revenue for the organ of state, and includes, but is not limited to, leasing and disposal of assets and concession contracts, excluding direct sales and disposal of assets through public auctions; and
- (e) **“the Act”** means the Preferential Procurement Policy Framework Act, 2000 (Act No. 5 of 2000).

## 3. FORMULAE FOR PROCUREMENT OF GOODS AND SERVICES

### 3.1. POINTS AWARDED FOR PRICE

#### 3.1.1 THE 80/20 OR 90/10 PREFERENCE POINT SYSTEMS

A maximum of 80 or 90 points is allocated for price on the following basis:

$$\begin{array}{ccc}
 \mathbf{80/20} & \mathbf{or} & \mathbf{90/10} \\
 \\
 \mathbf{Ps} = \mathbf{80} \left( \mathbf{1} - \frac{\mathbf{Pt} - \mathbf{Pmin}}{\mathbf{Pmin}} \right) & \mathbf{or} & \mathbf{Ps} = \mathbf{90} \left( \mathbf{1} - \frac{\mathbf{Pt} - \mathbf{Pmin}}{\mathbf{Pmin}} \right)
 \end{array}$$

Where

- Ps = Points scored for price of tender under consideration  
Pt = Price of tender under consideration  
Pmin = Price of lowest acceptable tender

### 3.2. FORMULAE FOR DISPOSAL OR LEASING OF STATE ASSETS AND INCOME GENERATING PROCUREMENT

#### 3.2.1. POINTS AWARDED FOR PRICE

A maximum of 80 or 90 points is allocated for price on the following basis:

$$Ps = 80 \left( 1 + \frac{Pt - Pmax}{Pmax} \right) \text{ or } Ps = 90 \left( 1 + \frac{Pt - Pmax}{Pmax} \right)$$

Where

- Ps = Points scored for price of tender under consideration  
Pt = Price of tender under consideration  
Pmax = Price of highest acceptable tender

### 4. POINTS AWARDED FOR SPECIFIC GOALS

4.1. In terms of Regulation 4(2); 5(2); 6(2) and 7(2) of the Preferential Procurement Regulations, preference points must be awarded for specific goals stated in the tender. For the purposes of this tender the tenderer will be allocated points based on the goals stated in table 1 below as may be supported by proof/ documentation stated in the conditions of this tender:

4.2. In cases where organs of state intend to use Regulation 3(2) of the Regulations, which states that, if it is unclear whether the 80/20 or 90/10 preference point system applies, an organ of state must, in the tender documents, stipulate in the case of—

- (a) an invitation for tender for income-generating contracts, that either the 80/20 or 90/10 preference point system will apply and that the highest acceptable tender will be used to determine the applicable preference point system; or
- (b) any other invitation for tender, that either the 80/20 or 90/10 preference point system will apply and that the lowest acceptable tender will be used to determine the applicable preference point system,

then the organ of state must indicate the points allocated for specific goals for both the 90/10 and 80/20 preference point system.



**Table 1: Specific goals for the tender and points claimed are indicated per the table below.**

*(Note to organs of state: Where either the 90/10 or 80/20 preference point system is applicable, corresponding points must also be indicated as such.*

*Note to tenderers: The tenderer must indicate how they claim points for each preference point system.)*

The specific goals allocated points in terms of this tender	Number of points allocated (80/20 system) (To be completed by the organ of state)	Tenderer to indicate number of points to be claimed (Number of points claimed to a maximum of 10 points )
100% Black owned entities	10	
The specific goals allocated points in terms of this tender	Number of points allocated (80/20 system) (To be completed by the organ of state)	Tenderer to indicate number of points to be claimed (Number of points claimed to a maximum of 10 points )
Enterprises located in a specific District (Proof of residence to be attached)	10	
51% Black people who are women	10	
51% Black people who are youth	8	
51% Black people with disabilities (Proof to be attached)	7	
51% Black people living in rural or underdeveloped areas or townships	6	
51% Black people who are military veterans (Proof to be attached)	6	
A cooperative owned by 51% black people	5	

**DECLARATION WITH REGARD TO COMPANY/FIRM**

- 4.3. Name of company/firm.....
- 4.4. Company registration number: .....

4.5. TYPE OF COMPANY/ FIRM

- Partnership/Joint Venture / Consortium
  - One-person business/sole propriety
  - Close corporation
  - Public Company
  - Personal Liability Company
  - (Pty) Limited
  - Non-Profit Company
  - State Owned Company
- [TICK APPLICABLE BOX]

4.6. I, the undersigned, who is duly authorised to do so on behalf of the company/firm, certify that the points claimed, based on the specific goals as advised in the tender, qualifies the company/ firm for the preference(s) shown and I acknowledge that:

- i) The information furnished is true and correct;
- ii) The preference points claimed are in accordance with the General Conditions as indicated in paragraph 1 of this form;
- iii) In the event of a contract being awarded as a result of points claimed as shown in paragraphs 1.4 and 4.2, the contractor may be required to furnish documentary proof to the satisfaction of the organ of state that the claims are correct;
- iv) If the specific goals have been claimed or obtained on a fraudulent basis or any of the conditions of contract have not been fulfilled, the organ of state may, in addition to any other remedy it may have –
  - (a) disqualify the person from the tendering process;
  - (b) recover costs, losses or damages it has incurred or suffered as a result of that person's conduct;
  - (c) cancel the contract and claim any damages which it has suffered as a result of having to make less favourable arrangements due to such cancellation;
  - (d) recommend that the tenderer or contractor, its shareholders and directors, or only the shareholders and directors who acted on a fraudulent basis, be restricted from obtaining business from any organ of state for a period not exceeding 10 years, after the *audi alteram partem* (hear the other side) rule has been applied; and
  - (e) forward the matter for criminal prosecution, if deemed necessary.

.....	
<b>SIGNATURE(S) OF TENDERER(S)</b>	
<b>SURNAME AND NAME:</b>	.....
<b>DATE:</b>	.....
<b>ADDRESS:</b>	.....
	.....
	.....
	.....

CONTRACT FORM - PURCHASE OF GOODS/WORKS

THIS FORM MUST BE FILLED IN DUPLICATE BY BOTH THE SUCCESSFUL BIDDER (PART 1) AND THE PURCHASER (PART 2). BOTH FORMS MUST BE SIGNED IN THE ORIGINAL SO THAT THE SUCCESSFUL BIDDER AND THE PURCHASER WOULD BE IN POSSESSION OF ORIGINALLY SIGNED CONTRACTS FOR THEIR RESPECTIVE RECORDS.

PART 1 (TO BE FILLED IN BY THE BIDDER)

- 1. I hereby undertake to supply all or any of the goods and/or works described in the attached bidding documents to (name of institution)..... in accordance with the requirements and specifications stipulated in bid number..... at the price/s quoted. My offer/s remain binding upon me and open for acceptance by the purchaser during the validity period indicated and calculated from the closing time of bid.
- 2. The following documents shall be deemed to form and be read and construed as part of this agreement:
  - (i) Bidding documents, viz
    - Invitation to bid;
    - Tax clearance certificate;
    - Pricing schedule(s);
    - Technical Specification(s);
    - Preference claims for Broad Based Black Economic Empowerment Status Level of Contribution in terms of the Preferential Procurement Regulations 2011;
    - Declaration of interest;
    - Declaration of bidder's past SCM practices;
    - Certificate of Independent Bid Determination
    - Special Conditions of Contract;
  - (ii) General Conditions of Contract; and
  - (iii) Other (specify) .
- 3. I confirm that I have satisfied myself as to the correctness and validity of my bid; that the price(s) and rate(s) quoted cover all the goods and/or works specified in the bidding documents; that the price(s) and rate(s) cover all my obligations and I accept that any mistakes regarding price(s) and rate(s) and calculations will be at my own risk.
- 4. I accept full responsibility for the proper execution and fulfilment of all obligations and conditions devolving on me under this agreement as the principal liable for the due fulfillment of this contract.
- 5. I declare that I have no participation in any collusive practices with any bidder or any other person regarding this or any other bid.
- 6. I confirm that I am duly authorised to sign this contract.

NAME (PRINT) .....

CAPACITY .....

SIGNATURE .....

NAME OF FIRM .....

DATE .....

WITNESSES	
1	.....
2.	.....
---	---

CONTRACT FORM - PURCHASE OF GOODS/WORKS

PART 2 (TO BE FILLED IN BY THE PURCHASER)

1. I **Ms PMM Nxumalo** in my capacity as **Deputy Director: Acquisition** accept your bid under reference number R/S/2425/.....dated ...../...../2024 for the supply of goods/works indicated hereunder and/or further specified in the annexure(s).
2. An official order indicating delivery instructions is forthcoming.
3. I undertake to make payment for the goods/works delivered in accordance with the terms and conditions of the contract, within 30 (thirty) days after receipt of an invoice accompanied by the delivery note.

ITEM NO.	PRICE (ALL APPLICABLE TAXES INCLUDED)	BRAND	DELIVERY PERIOD	B-BBEE STATUS LEVEL OF CONTRIBUTION	MINIMUM THRESHOLD FOR LOCAL PRODUCTION AND CONTENT (if applicable)
		AS PER SPECIFICATION			

4. I confirm that I am duly authorised to sign this contract.

SIGNED AT **CEDARA** ON ...../...../2024

NAME (PRINT) **PMM NXUMALO**

SIGNATURE .....

OFFICIAL STAMP 

**WITNESSES**

1. ....

2. ....

DATE ...../...../2023



Cedara Road, Pietermaritzburg, 3200

ZN Department of Agriculture & Rural Development, Private Bag X9059, Pietermaritzburg, 3200

Phone: 033 355 9588 / 9369

**Procurements from R1 up to R 30 000.00, the Department will allocate (80/20) points as follows:**

80 points for price

10 points for black owned entities

10 points for entities located in a District where goods/services are required.

If the entity is 100% owned by black people, this must be supported by a BBBEE certificate or affidavit or share register or CSD report.

<b>Historically Disadvantaged Individuals</b>	<b>Black Owned</b>	<b>Districts</b>	<b>Total Points</b>
<b>An EME or QSE which is at least 100% owned by black people</b>			
Enterprises located in a specific District for work to be done or services to be rendered in that District (Proof of residence to be attached)	<b>10</b>	<b>10</b>	<b>20</b>



**Procurements from R30 000 – R1M the Department will allocate the points as follows**

<b>Historically Disadvantaged Individuals</b>	<b>Black Owned</b>	<b>Points</b>
<b>0An EME or QSE which is at least 100% owned by black people</b>		
51% Black people who are women	10	10
51% Black people who are youth	10	8
51% Black people with disabilities ( <b>Proof to be attached</b> )	10	7
51% Black people living in rural or underdeveloped areas or townships	10	6
51% Black people who are military veterans ( <b>Proof to be attached</b> )	10	6
A cooperative owned by 51% black people	10	5

If the entity is 100% owned by black people, this must be supported by a BBBEE Certificate or Affidavit or Share Register or CSD report.

Should the service provider qualify for more than one (1) specific goal points as per the above table, the Department will allocate the points to the goal with highest score.